

***B Series***

**NEW AGE**



***7210B***

***7240B***

***Ferrari***

***PASSION FOR LIFTING***

# 7210B - 7240B Technical data

	Lifting Moment	Swiveling Angle	Working pressure	Oil tank capacity	Max Oil flow	Max lifting height	Standard crane weight
	tm	°	bar	l	l/min	m	kg
<b>7210B</b>							
A2	18,9	415	315	130	70	11,9	2305
A3	18,5	415	315	130	70	13,9	2455
A4	18,0	415	315	130	70	16,1	2600
A5	17,6	415	315	130	70	18,2	2715
<b>7240B</b>							
A2	22,7	415	320	130	80	11,9	2485
A3	21,8	415	320	130	80	13,9	2510
A4	21,1	415	320	130	80	16,0	2555
A5	20,4	415	320	130	80	18,2	2710

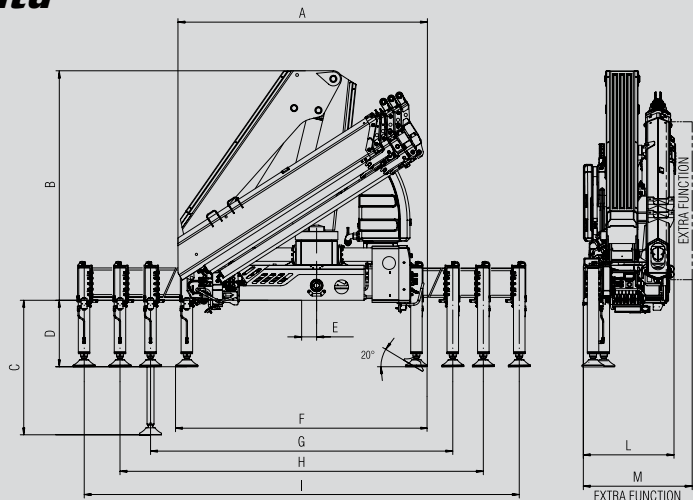

	A2	A3	A4	A5
A	2500	2500	2500	2500
B	2300	2300	2300	2300
C	1348	1348	1348	1348
D	611	611	611	611
E	150	150	150	150
F	2520	2520	2520	2520
G	4860	4860	4860	4860
H	5500	5500	5500	5500
I	7420	7420	7420	7420
L	930	930	930	930
M	1050	1050	1050	1050

<b>A2</b>	kg	4455	3020	2290				<b>7210B</b>		
	m	4,25	6,15	8,05						
	kg	5340	3635	2765				<b>7240B</b>		
	m	4,25	6,15	8,05						
<b>A3</b>	kg	4370	2990	2240	1705	1285	980	770	<b>7210B</b>	
	m	4,25	6,15	8,05	10,08	12,20	14,41	16,54		
	kg	5140	3450	2585	2045	1535	1170	770	<b>7240B</b>	
	m	4,25	6,15	8,05	10,08	12,20	14,41	16,54		
<b>A4</b>	kg	4145	2850	2130	1630	1285	980	770	630	<b>7210B</b>
	m	4,34	6,24	8,14	10,17	12,20	14,41	16,54	18,65	
	kg	4875	3240	2390	1865	1535	1170	915	735	<b>7240B</b>
	m	4,34	6,24	8,14	10,17	12,20	14,41	16,54	18,65	
<b>A5</b>	kg	3980	2605	1890	1445	1165	980	770	630	<b>7210B</b>
	m	4,42	6,32	8,22	10,25	12,28	14,41	16,54	18,65	
	kg	4635	3055	2230	1715	1395	1170	915	735	<b>7240B</b>
	m	4,42	6,32	8,22	10,25	12,28	14,41	16,54	18,65	

## Standard

- Designed in accordance with EN12999
- Design class: HC1-HD4
- Cross controls
- Load limit device
- Flanged valves
- Oil tank
- Manually extendable stabilizers
- Internal stabilizers pipes
- Fixed stabilizer cylinders
- Swivel stabilizer foot
- Centralized greasing system
- EQS Extension Quick System
- SDV Smooth Descent Valve
- F3XL Crane control system (CE)



## F.lli FERRARI

Via Einstein, 8  
42028 Poggio (RE) Italy  
Tel. +39 0522/486308  
Fax +39 0522/486330  
info@fliferrari.it  
marketing@fliferrari.it  
www.fliferrari.com



Quality and environmental  
certified

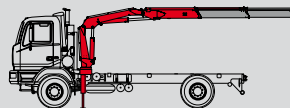

Recommended truck:  
**7210B** - M.T.T. ton 17 - G.V.W. ton 17  
**7240B** - M.T.T. ton 19 - G.V.W. ton 19

Dealer

Data, descriptions, and illustrations pertain only and uniquely to models sold at the time of printing of this brochure. After the date of printing, this information is purely indicative and not binding upon F.lli Ferrari. Future modifications are solely at the discretion of F.lli Ferrari and are always in compliance with applicable and pertinent safety standards. To obtain updated data, descriptions, and illustrations, contact the manufacturer or your reseller. Cranes manufactured and/or marketed by F.lli Ferrari.